



Click on the button for the level you need:

Brownies

Juniors

Cadettes

Seniors and Ambassadors



Outdoor Skills Patch Knots – Brownies



Learn the skills needed to thrive in an outdoor environment. Do you know how tie knots and what to use them for? Do you want to learn games you can play using knots?

PLEASE NOTE:

- Feel free to use the internet to look for videos and other diagrams of how to tie the knots in this section as it may be easier to understand than written text.
- Try to space out each step between different troop meetings, different times during an overnight campout, etc. Doing them one right after another might cause the girls to become disinterested and less engaged.
- The girls will remember less if you try to cram all of these into one troop meeting or lesson.

Step 1:

Learn overhand, square, and slip knots

1. Gather the girls up and explain “Today we are going to learn about different types of knots. What do you think we use knots for?”
 - a. Knots can be used to tie things together, to stop rope from going through holes, to wrap rope around poles, etc.
 - b. You use knots in activities like: sailing, climbing, caving, fishing, firefighting, truck driving and surgery.
2. “Awesome! Now, there are lots of different knots that exist and they all do different things. It’s important to learn how to tie different types of knots and what they are used for because if you use the wrong knot, it could be dangerous.”
 - a. Before going into the next steps, it might be helpful to print off images of the knots below so girls can see the diagrams as they are working on the knots. See the resources at the end of this document.

➔ OVERHAND KNOT

Materials Needed: 1 piece of rope for each girl – about 3 feet long

3. “First we’re going to learn how to tie an overhand knot (first step of tying their shoes if they need a reference). Overhand knots are used when just a simple knot is needed.”
 - a. Make "Q" shape. Cross the end of the rope over the top of the remaining rope, making a "Q" shape.
 - b. Tuck end through loop.
 - c. Tighten.
 - d. The easiest stopper knot to tie, the Overhand is used to keep a rope from slipping out of a hole through which it has been threaded.
4. Let the girls practice tying the knot a few times. If some girls are struggling, try pairing them up with girls who are tying the knot well.
5. “Wow those are some great overhand knots! Can anyone come up with any ways that we could use this knot?” Let the girls answer.

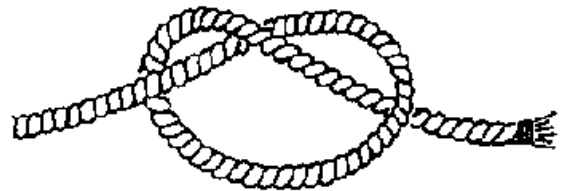
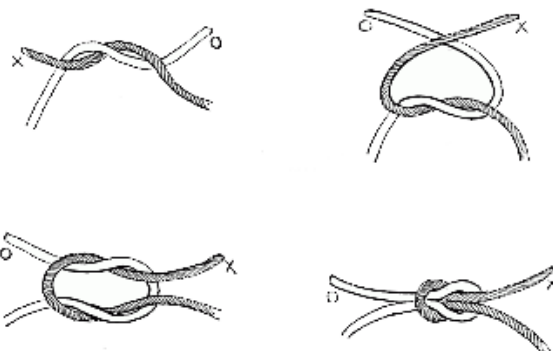

Fig. 5
Overhand Knot

➔ **SQUARE KNOT**

Materials Needed: 1 piece of rope for each girl – about 3 feet long

6. Now we are going to learn how to tie a square knot. Square knots are used to join two pieces of rope that are the same width or two ends together."
 - a. Hold one end of a rope in your right hand and one end in your left to prepare to tie the knot. (You can also use two different colored ropes which makes it easier because you can say yellow rope and green rope instead of left and right hands.)
 - b. Loop the right end over the left end all the way around (right over left).
 - c. Loop the left end, formerly the right end, over the right end all the way around (then left over right).
 - d. Pull on all four strands at the same time. This should tighten the knot into place, resulting in a square knot.



7. Let the girls practice tying the knot a few times. If some girls are struggling, try pairing them up with girls who are tying the knot well.
8. "Wowza those are some great square knots! Can anyone come up with any ways that we could use this knot?" Let the girls answer.

➔ **SLIP KNOT**

Materials Needed: 1 piece of rope for each girl – about 3 feet long

9. "Now we are going to learn how to tie a slip knot. Slip knots are used when you need a loop that you can change the size of."
 - a. Hold the rope with two hands and form a loop by bringing the rope in the right hand under the rope in the left hand so that the rope crosses.
 - b. Secure the loop with your left hand where the rope crosses.
 - c. Reach your right hand through the loop and grab a hold of the rope on the left side.
 - d. Pull your right hand back through the loop.
 - e. Let go with your left hand, and then grab onto the two hanging ends.
10. To finish the slip knot, pull your hands away from each other, twisting your right hand clockwise until the knot is tight.
11. Let the girls practice tying the knot a few times. If some girls are struggling, try pairing them up with girls who are tying the knot well.
12. "Gee wiz! Those are some great slip knots! Can anyone come up with any ways that we could use this knot?"

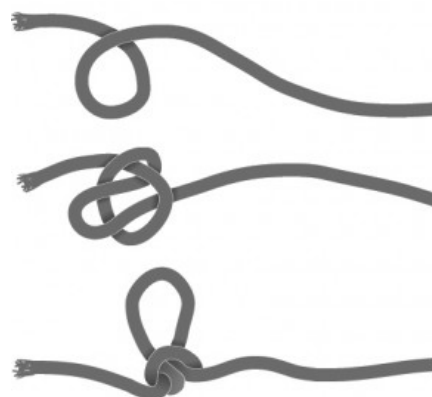

➡ PRACTICE TIME WITH ALL THREE KNOTS

Materials Needed: 1 piece of rope for each girl – about 3 feet long

13. “Those are the three knots that we are going to start off with today. Now that we know how to tie them, let’s see if we can remember them all!”
14. Have the girls practice the three knots in order to help retain what they just learned.
 - a. You can have the three types of knots written on pieces of paper and have the girls each draw a slip of paper. Then they complete the knot on their paper. Repeat a few times.
 - b. You can have three girls get together and tie all three knots, checking each other’s knots to see if they are right.
 - c. Or any other ideas the girls might have to show they know how to tie these three knots.
15. Give girls either a rope to take home or some time later to practice tying knots on their own. The best way to remember how to tie knots is to tie them a lot!

Step 2:

Learn an overhand on a bight and a figure 8 knot

1. Gather the girls up and explain “Today we are going to learn 2 more types of knots. But first, let’s review the knots we learned last time!”
 - a. Review the overhand, square, and slip knots. Refer to Step 1 for instructions.
 - b. Before going into the next steps, it might be helpful to print off images of the knots below so girls can see the diagrams as they are working on the knots. See the resources at the end of this document.

➡ OVERHAND ON A BIGHT KNOT

Materials Needed: 1 piece of rope for each girl – about 3 feet long

2. “Awesome! Now we’re going to learn how to tie an overhand on a bight. What do you think ‘on a bight’ means?”
 - a. A “bight” is a curved section between two ends of a rope. Any section of rope that is bent into a U-Shape.
 - b. To make an overhand on a bight, we are going to tie the rope in the same way as the normal overhand just using a bight in the rope on one end.
 - i. Make "Q" shape. Cross the end of the rope over the top of the remaining rope, making a "Q" shape.
 - ii. Tuck end through loop.
 - iii. Tighten.
3. Let the girls practice tying the knot a few times. If some girls are struggling, try pairing them up with girls who are tying the knot well.

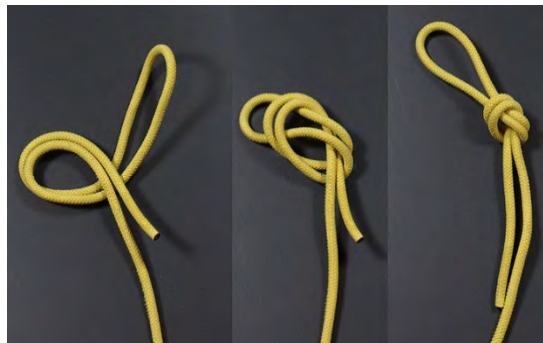

4. "Wowza those are some great overhand on a bight knots! Can anyone come up with any ways that we could use this knot?"
 - a. To attach a carabiner, to loop around a post, when you need a quick and easy loop.

➔ **FIGURE EIGHT KNOT**

Materials Needed: 1 piece of rope for each girl – about 3 feet long

5. "Now we are going to learn how to tie a figure eight knot. Figure eight knots are used as stopper knots and in climbing."
 - a. Pass the tail over itself to form a loop.
 - b. Continue under and around the standing end.
 - c. Complete the knot by passing the tail down through the loop.
 - d. Tighten
6. Let the girls practice tying the knot a few times. If some girls are struggling, try pairing them up with girls who are tying the knot well.

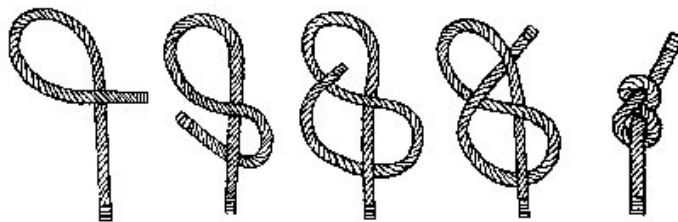

7. "Amazing! Those are some great figure eight knots! Can anyone come up with any ways that we could use this knot?"

➔ **TEAM CHALLENGE**

Materials Needed: 1 piece of rope for each girl – about 3 feet long, 1 small blanket or towel, a smooth surface

8. "Now we are going to put our knots to the test! Through a team building knot challenge!"
 - a. Explain to the girls that through the different knots they have learned, they will need to work together to complete the challenge in front of them. Everyone needs to tie at least one knot and everyone's piece of rope needs to be used.
 - b. Have one person sit on the blanket or towel about 15 feet away from the group (adjust the distance depending on the number of girls in the group). Ideally this is a leader or another person in the area, but this could be a girl if needed.
 - c. Say to the girls: "
 - i. Today we were out for a canoe ride and it was so much fun. We were all getting out of our boats onto the dock that we are all standing on, then when (person on the blanket) tried to get out of her canoe, a huge gust of wind came sweeping in and now she is just left floating in the middle of the lake without her paddle. We can't get back in our boats because they have all been put away already. But luckily you girls all have your piece of rope! You can save her now! Working together let's get our rope long enough to reach her and give her a handle to grab onto so we can pull her in."
 - ii. "Remember everyone needs to tie at least one knot and everyone's piece of rope needs to be used."
 - d. Example of how to get this done: each girl will tie a square knot connecting her piece of rope to the girl's next to hers. The last girl can tie an overhand on a bight to use as a handle for the person on the blanket to hold onto. Working together they can all pull the person to safety.
 - i. Girls may also be able to complete this in other ways. Encourage creativity!

Step 3:

Play knot tying games and make knot dolls

1. Gather the girls up and explain “Today we are going to review our knots and play some fun games with them!”
 - a. Review the overhand, square, slip, overhand on a bight, and figure eight knots. Refer to Steps 1 and 2 for instructions.

➔ **TEST OF STRENGTH**

Materials Needed: 1 piece of rope for each girl – about 3 feet long

2. Have the girls stand in a circle holding their ropes (try to spread out the girls so sizes are intermixed so that weight will be distributed somewhat evenly when they lean back).
3. Each girl ties one end of her rope with a square knot to the rope of the girl on her left. Have the girls double check each other’s knots. Have an adult walk around and check the knots too.
4. When all knots are tied, have the girls put their feet shoulder width apart with their knees slightly bent. On the count of three, have the girls all lean back, putting their weight on the rope, keeping their arms straight out in front of them.
5. The square knot can tie ropes together and hold a lot of weight as well! It is super strong!

➔ **CANDY GAME**

Materials Needed: 1 dice, several pieces of fun sized candy

6. Have the girls sit in a circle with the candy pieces in the middle.
7. Go around the circle and have every girl toss the dice; having them see what knot their number connects with:
 - a. Overhand = 1
 - b. Square = 2
 - c. Slip = 3
 - d. Overhand on a bight = 4
 - e. Figure 8 on a bight = 5
 - f. Knot of your choice = 6
8. Once all the girls know what knot they are to tie, have them tie it. Once they have it done, have them double check each other’s knots. If they are correct, they can get one piece of candy. They can help support each other as well if someone is having trouble tying their knot.

➔ **KNOT DOLL**

Materials Needed: 1 piece of cord for each girl – about 3 feet long, 1 piece of cord for each girl about 10 inches long

9. Girls will use the knots they’ve practiced to create a knot doll
10. Tie the following knots in the following order:
 - a. Fold a 3 foot rope in half. Make the head using an overhand on a bight.
 - b. About half way down, tie the hips using a square knot.
 - c. Tie the feet individually using a figure 8
 - d. Attach the arms (separate piece of rope) using an overhand knot to tie it on to the body of the doll.
 - e. To make the hands, tie an overhand knot at each end.
11. Have the girls give a name to their rope doll!
12. Congratulate the girls on all their new knots they know how to tie! Remind them that the best way to remember the knots is to keep tying them just for fun!
13. Challenge them to find new ways to use their knots and share with the group at a later time.

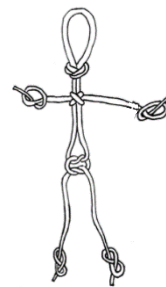

Resources:
Knot Handout

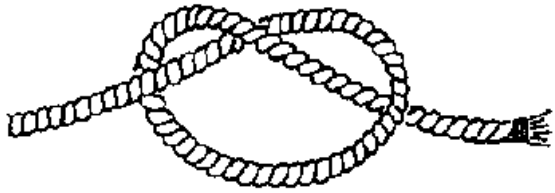

OVERHAND KNOT

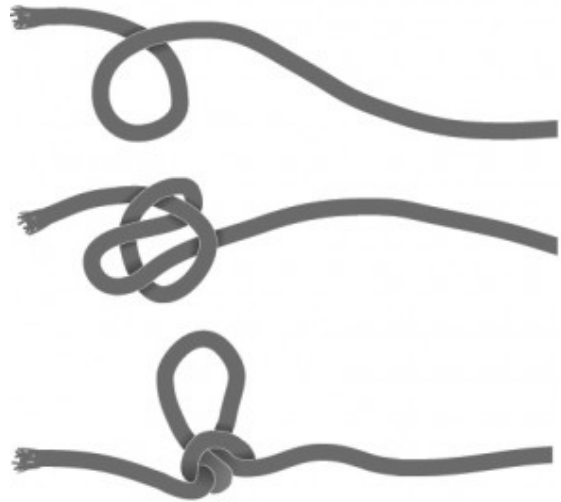

SLIP KNOT

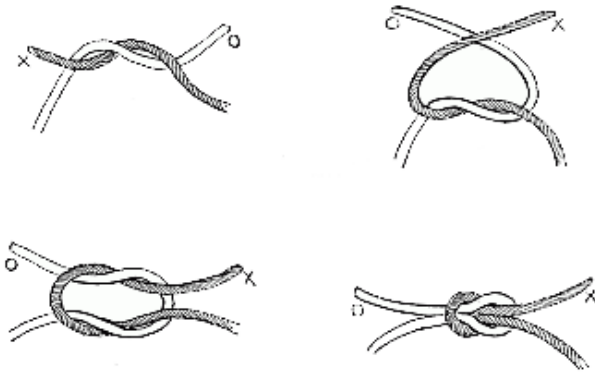

SQUARE KNOT



OVERHAND ON A BIGHT

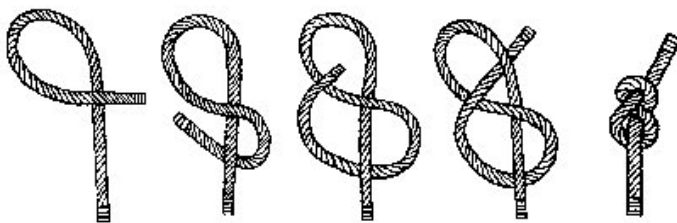
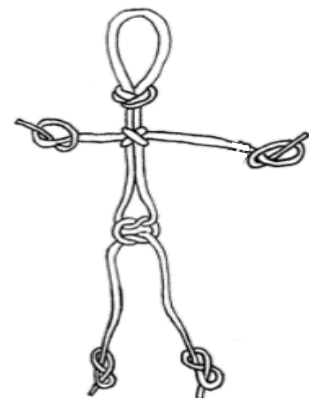

FIGURE EIGHT



KNOT DOLL



Outdoor Skills Patch Knots – Juniors



Learn the skills needed to thrive in an outdoor environment. Do you know how to tie knots and what to use them for? Do you want to use knots with outdoor activities?

PLEASE NOTE:

- Feel free to use the internet to look for videos and other diagrams of how to tie the knots in this section as it may be easier to understand than written text.
- Try to space out each step between different troop meetings, different times during an overnight campout, etc. Doing them one right after another might cause the girls to become disinterested and less engaged.
- The girls will remember less if you try to cram all of these into one troop meeting or lesson.

Step 1:

Learn the water knot, double overhand, and bowline

1. Gather the girls up and explain “Today we are going to learn about different types of knots. What do you think we use knots for?”
 - a. Knots can be used to tie things together, to stop rope from going through holes, to wrap rope around poles, etc.
 - b. You use knots in activities like: sailing, climbing, caving, fishing, firefighting, truck driving and surgery.
2. “Awesome! Now, there are lots of different knots that exist and they all do different things. It’s important to learn how to tie different types of knots and what they are used for because if you use the wrong knot, it could be dangerous.”
3. “First we’re going to review some knots that we’ve learned in the past!”
 - a. Review the **overhand, square, slip, overhand on a bight, and figure 8 knot**.
 - b. Refer to Brownie Knots Steps 1 and 2 or look online for how to tie these knots.
 - c. If you did not learn these knots in Brownies, teach them to your girls at this time. These are basic knots the girls should know.

➔ WATER KNOT

Materials Needed: 1 piece of webbing for each girl – about 3 feet long

4. “Now that we’ve reviewed some knots, we’re going to learn how to tie a water knot. A water knot is used to join 2 pieces of webbing or 2 ends of webbing together.”
 - a. Tie an overhand knot in one end.
 - b. With the other end, trace-back the path of the overhand knot.
 - c. Make sure the tracing is complete.
 - d. Adjust the knot so both tails (ends of the webbing) are at least 3”, and pull tight.
5. Let the girls practice tying the knot a few times. If some girls are struggling, try pairing them up with girls who are tying the knot well.

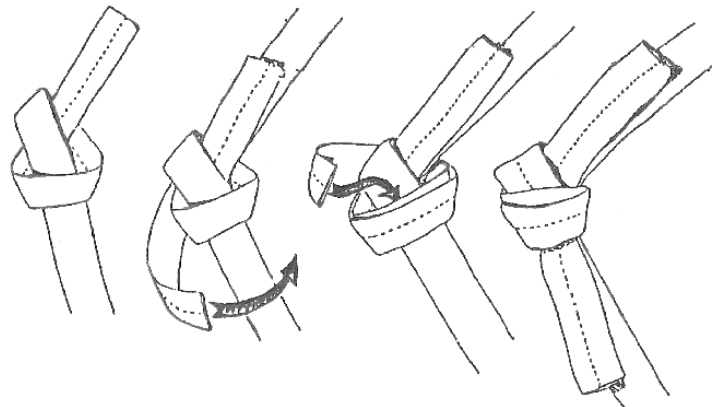

6. “Those are some amazing water knots! Can anyone come up with any ways that we could use this knot?”
 - a. Used for rock climbing, team building games, used to join together flat pieces like leather and ribbon
7. Now that we’ve learned this knot, we’re going to play a little game.
 - a. Have the girls stand in a circle holding their webbing (try to spread out the girls so sizes are intermixed so that weight will be distributed somewhat evenly when they lean back).
 - b. Each girl ties one end of her webbing with a water knot to the rope of the girl on her left. Have the girls double check each other’s knots. Have an adult walk around and check the knots too.
 - c. When all knots are tied, have the girls put their feet shoulder width apart with their knees slightly bent. On the count of three, have the girls all lean back, putting their weight on the rope, keeping their arms straight out in front of them.
 - d. The water knot can tie flat pieces of webbing together and hold a lot of weight as well! It is super strong!

➔ **DOUBLE OVERHAND KNOT**

Materials Needed: 1 piece of rope for each girl – about 3 feet long

8. “Now we are going to learn how to tie a double overhand knot. Double overhand knots are used as a reliable, moderately large stopper knot.”
 - a. Form a loop in the rope.
 - b. Pass the end through it.
 - c. Pass the end through the loop again.
9. Let the girls practice tying the knot a few times. If some girls are struggling, try pairing them up with girls who are tying the knot well.
10. “Amazing those are some great double overhand knots! Can anyone come up with any ways that we could use this knot?”

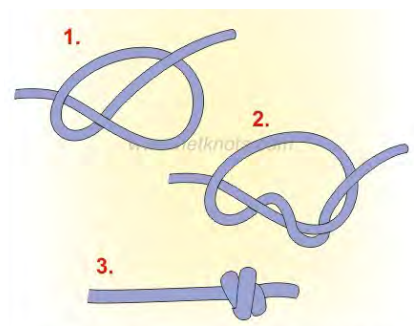

➔ **BOWLINE**

Materials Needed: 1 piece of rope for each girl – about 6 feet long

11. “Stellar! Now we are going to learn how to tie a bowline (pronounced boe-lin). A bowline is used to form a non-slip loop in the end of a rope.”
 - a. Form a small loop, leaving enough rope for the desired loop size.
 - b. Pass the end of the rope through the loop as though making an overhand knot.
 - c. Continue around the standing end and then back through the small loop.

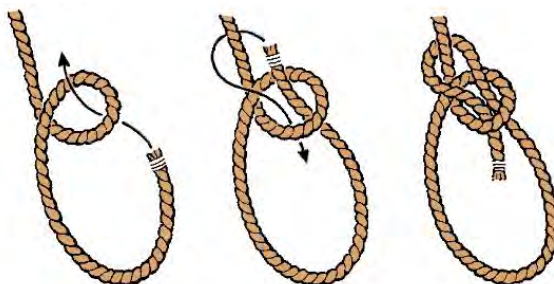

12. Let the girls practice tying the knot a few times. If some girls are struggling, try pairing them up with girls who are tying the knot well.
13. “Wowzers those are some great bowlines! Can anyone come up with any ways that we could use this knot?”

- a. When you need to rescue someone, it can go around their waist and not tighten on them as the other end gets pulled. To tie around an object that you don't want the loop size to change on. Sailing.
14. "Now we are going to put our knot tying skills to a test!"
 - a. Have the troop divide into pairs. Each pair lines up across from each other. Each girl is given a piece of rope long enough to tie around her waist with a couple of extra feet. These ropes should be on the ground by the scout's feet.
 - b. At the GO signal, each scout picks up her rope and ties a bowline around her waist. Then they join the rope with their partner's rope using a square knot. They then back up until the ropes become taught and hold their hands in the air.
 - c. The first team done and with their knots tied correctly wins.
 - d. Make sure to keep playing until all girls have completed the challenge. Have the girls once finished cheer on the other teams.

Step 2:

Learn the clove hitch, munter's hitch, and quick release knot

1. Gather the girls up and explain "Today we are going to learn 3 more types of knots. But first, let's review the knots we learned last time!"
 - a. Review the water, double overhand, and bowline knots. Refer to Step 1 for instructions.

➔ CLOVE HITCH

Materials Needed: 1 piece of rope for each girl – about 3 feet long, a carabiner or post for girls to make hitches around

2. "Awesome! Now we're going to learn how to tie a clove hitch. A clove hitch is used to secure a rope to a post and won't slip around."
3. "There are 2 ways to tie a clove hitch, the first is making loops, and this one is useful when you have a top of a post you can slide it over or can insert it into an opening like a carabiner."
 - a. Form a loop in the rope.
 - b. Then form a second one – "the same way up." Both loops should be identical.
 - c. Cross the loops one above the other so they form a knot – instead of just two loops stacked on each other.
 - d. Place the knot over the post or into the carabiner.
4. "The second way is when you have a post that you don't have access to either end of."
 - a. Pass the end of the rope around the pole.
 - b. Take the end that went behind the pole and lay it over the other end of the rope (making an "x" shape).
 - c. Take that top rope and put it behind the post again.
 - d. When it comes back to the front, lift up the "x" shape and slide it under.
 - e. Pull tight to form the clove hitch.
5. Let the girls practice tying the knot both ways a few times. If some girls are struggling, try pairing them up with girls who are tying the knot well.
6. "Amazing those are some great clove hitches! Can anyone come up with any ways that we could use this knot?" Tying a rope between two poles/trees is the most common way it is used – like a clothes line.

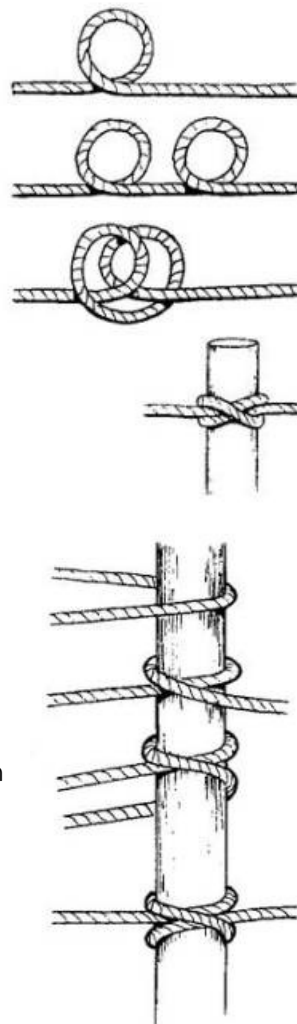

➔ **MUNTER HITCH**

Materials Needed: 1 piece of rope for each girl – about 3 feet long, a carabiner or post for girls to make hitches around

7. “Now we are going to learn how to tie a munter’s hitch. Munter’s hitches are used wrap around a post when you want the rope to move. They are also used a lot in rock climbing and canyoneering.”
 - a. Pass the rope into the carabiner (or like object).
 - b. Twist the rope above into a loop and hook it onto the carabiner.
8. Let the girls practice tying the knot a few times. If some girls are struggling, try pairing them up with girls who are tying the knot well.
9. “Geewiz those are some great munter hitches! Can anyone come up with any ways that we could use this knot?”
 - a. Emergency climbing/rescue situations as a belay tool.

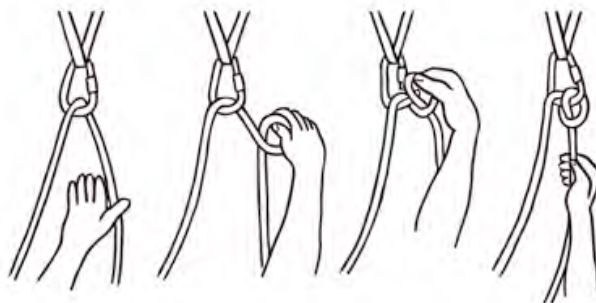

➔ **QUICK RELEASE KNOT**

Materials Needed: 1 piece of rope for each girl – about 3 feet long, a carabiner or post for girls to make knot around

10. “Awesome Sauce! Now we are going to learn how to tie a quick release knot. Quick release knots are used when working with horses.”
 - a. Put the end of the rope through the tie ring/ around the post/or similar object.
 - b. Wrap the loose end once around the rope, creating a circle.
 - c. Fold the loose end into a loop, and pull it through the circle.
 - d. If your horse is mouthy, tuck the loose end through the loop so that he can't untie himself.
11. Let the girls practice tying the knot a few times. If some girls are struggling, try pairing them up with girls who are tying the knot well.
12. “Amazing, those are some great quick release knots! Can anyone come up with any other ways that we could use this knot?”
13. Optional: To put these knots to practice, go horse backing riding with your girls and let them practice tying the horses up themselves.

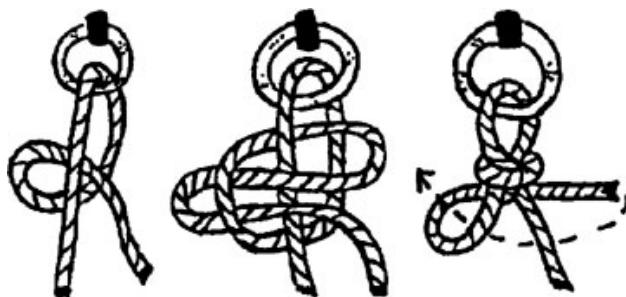

Step 3:

Learn the figure 8 on a bight and with a follow through and monkey chain

1. Gather the girls up and explain “Today we are going to learn 3 more types of knots. But first, let’s review the knots we learned last time!”
 - a. Review the water knot, double overhand knot, bowline knot, clove hitch, munter’s hitch, and quick release knot. Refer to Steps 1 and 2 for instructions.
 - b. Have the girls get into smaller groups of 3-6 people, each person having their own rope.
 - c. Give each group a set of index cards or pieces of paper with one knot per card/paper written on it.
 - d. Ask the girls to work together as a team to complete each knot.

➔ FIGURE 8 ON A BIGHT

Materials Needed: 1 piece of rope for each girl – about 3 feet long, a carabiner or post for girls to make knot around

2. “First we’re going to learn 2 variations of the figure 8 knot. The figure eight knot is one of the strongest knots and is most often used in rock climbing.”

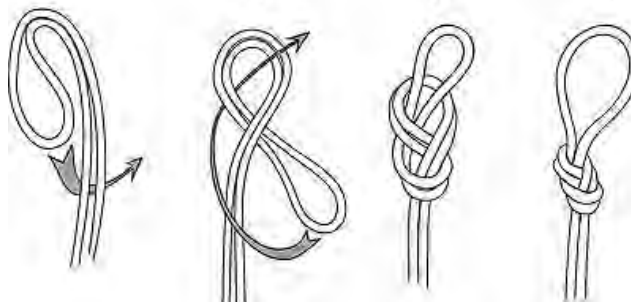

- a. We’ll start off with learning a figure eight on a bight.
 - i. Take a bight of rope.
 - ii. Pass the bite over itself to form a loop.
 - iii. Continue under and around the standing end.
 - iv. Complete the knot by passing the bite down through the loop.
 - v. Tighten
- b. Let the girls practice tying the knot a few times. If some girls are struggling, try pairing them up with girls who are tying the knot well.

➔ FIGURE 8 WITH A FOLLOW THROUGH

Materials Needed: 1 piece of rope for each girl – about 3 feet long, a carabiner for girls to make knot around

3. Now we are going to try the figure 8 with a follow through
 - a. Start by tying a loose figure 8 knot. Leave a long tail for the follow through.
 - b. Pass the tail through a carabiner.
 - c. Follow the original figure 8 around the entire knot in reverse.
 - d. Exit beside the standing end to complete a two stranded figure 8 knot.

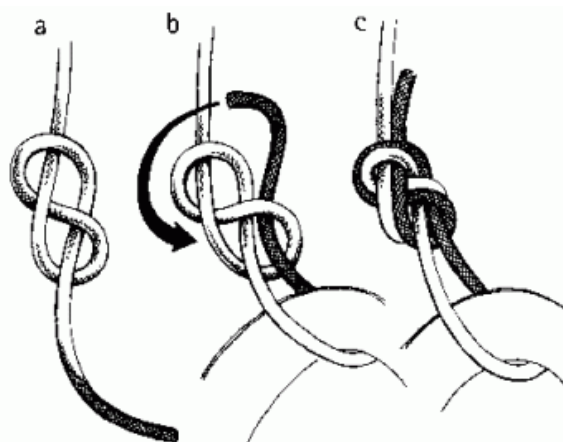

4. Let the girls practice tying the knot a few times. If some girls are struggling, try pairing them up with girls who are tying the knot well.
5. “Gee those are some great figure eights! Can anyone come up with any ways that we could use this knot?”
6. “What is the purpose of having 2 different ways to tie this knot?”

➔ **MONKEY CHAIN**

Materials Needed: 1 piece of rope for each girl – about 3 feet long

7. Now we are going to learn how to monkey chain rope (also known as a daisy chain). This is used when a rope is hanging, but you want to temporarily tie it up.
 - a. Make a loop in the rope.
 - b. Form another loop and tuck it into the first loop.
 - c. Make another loop and tuck it into the previous loop. Keep repeating.
 - d. When the chain is long enough, lock it by passing the end through the final loop.
 - e. With an untucked end, you should be able to just pull the end and unravel your chain.
8. Let the girls practice tying the knot a few times. If some girls are struggling, try pairing them up with girls who are tying the knot well.
9. “Amazing those are some great monkey chains! Can anyone come up with any ways that we could use this knot?”
10. Optional: After you have learned how to tie all these climbing knots, go climbing with your girls and let them try out tying the knots themselves!



Resources:
Knot Handout

Outdoor Skills Patch | Knots – Juniors

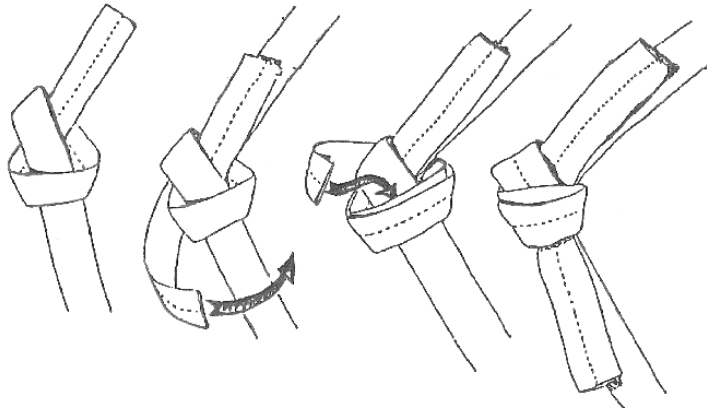

WATER KNOT

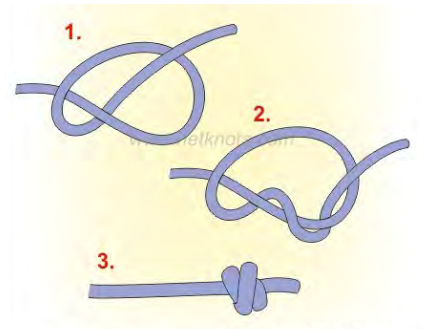

DOUBLE OVERHAND KNOT

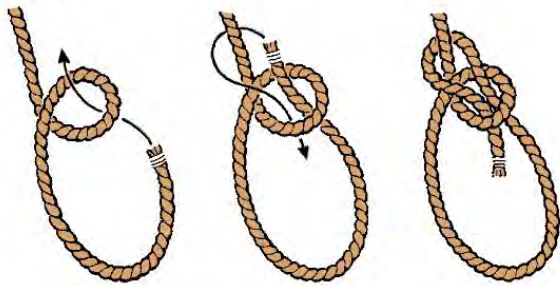

BOWLINE

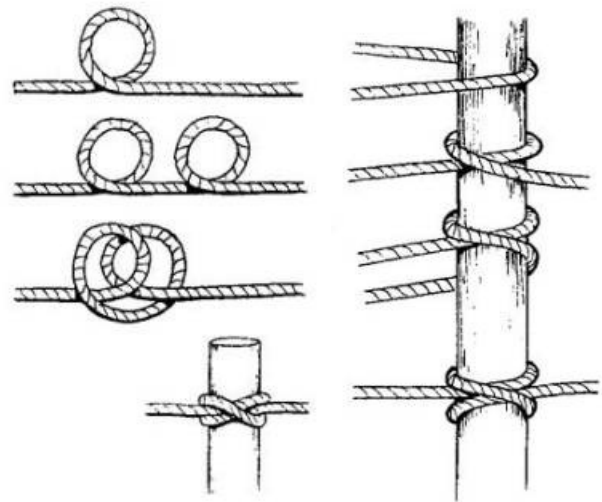

CLOVE HITCH

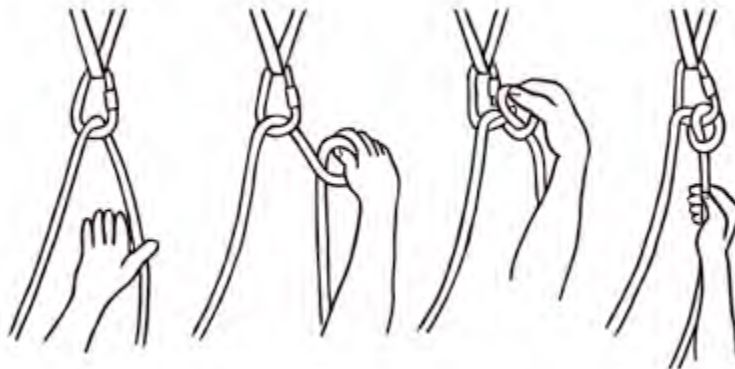

MUNTER HITCH

Outdoor Skills Patch | Knots – Juniors

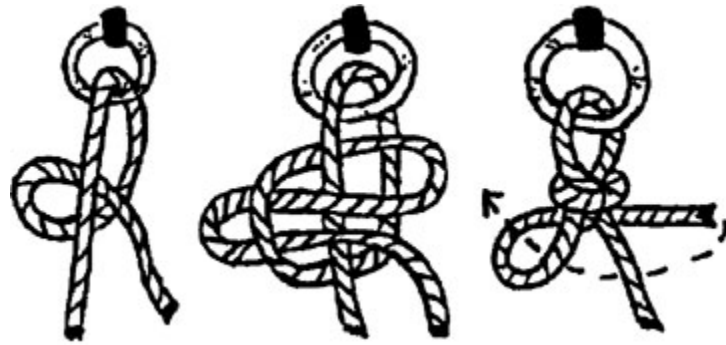

QUICK RELEASE KNOT

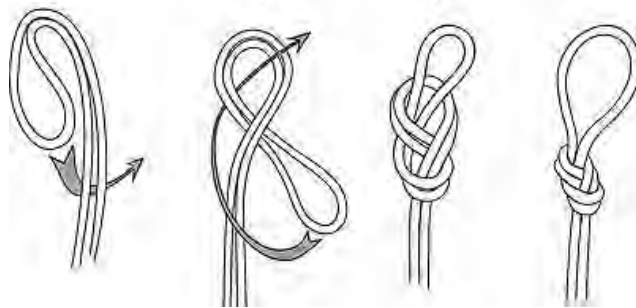

FIGURE EIGHT ON A BIGHT

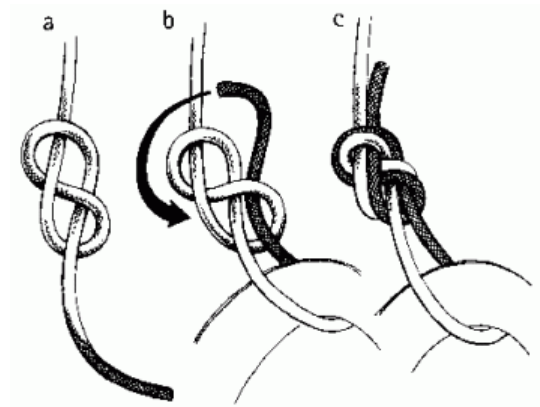

FIGURE EIGHT WITH A FOLLOW THROUGH



MONKEY CHAIN



Outdoor Skills Patch Knots – Cadettes



Learn the skills needed to thrive in an outdoor environment. Do you know how to tie knots and what to use them for? Do you want to use knots for unique jewelry projects?

PLEASE NOTE:

- Feel free to use the internet to look for videos and other diagrams of how to tie the knots in this section as it may be easier to understand than written text.
- Try to space out each step between different troop meetings, different times during an overnight campout, etc. Doing them one right after another might cause the girls to become disinterested and less engaged.
- The girls will remember less if you try to cram all of these into one troop meeting or lesson.

Step 1:

Learn the double fisherman's, trucker's hitch, and sheet bend

1. Gather the girls up and explain "Today we are going to learn different types of knots. What do you think we use knots for?"
 - a. Knots can be used to tie things together, to stop rope from going through holes, to wrap rope around poles, etc.
 - b. You use knots in activities like: sailing, climbing, caving, fishing, firefighting, truck driving and surgery.
2. "Awesome! Now, there are lots of different knots that exist and they all do different things. It's important to learn how to tie different types of knots and what they are used for because if you use the wrong knot, it could be dangerous."
3. "First we're going to review some knots that we've learned in the past!"
 - a. Review the knots from the Brownie and Junior Knots curriculum guides or look online for resources:
 - i. Brownies: overhand, square, slip, overhand on a bight, and a figure 8 knot
 - ii. Juniors: water, double overhand, bowline, clove hitch, munter's hitch, quick release knot, figure 8 on a bight and with a follow through and monkey chain
 - b. Be sure you can demonstrate that you know how to tie these knots and why you'd use these knots.
 - c. Optional: See how fast, while still accurate, you can tie certain knots while having your eyes closed!
 - d. The best way to remember how to tie knots is to keep tying them!

➔ **DOUBLE FISHERMAN'S**

Materials Needed: 1 piece of rope for each girl – about 3 feet long, cord or sting for necklaces, beads (optional) for necklaces

4. "Now that we've reviewed some knots, we are going to learn how to tie a double fisherman's knot. Double fisherman's knots are used to combine two pieces of rope together."
 - a. Set the two ends together, each pointing in opposite directions.
 - b. Wrap one end around both ropes two times. Pass this end back through the loops that these turns created and pull tight.

- c. Do the same on the other side: wrap the other end two times around both ropes. Pass this end back through and pull tight.
 - d. Make sure both sides of the knot sit against each other (if they don't, untie one end, and try wrapping it in the other direction).
 - e. Pull on both ropes tight to cinch the two knots against each other
5. Let the girls practice tying the knot a few times. If some girls are struggling, try pairing them up with girls who are tying the knot well.
 6. "Those are some great double fisherman's knots! Can anyone come up with any ways that we could use this knot?"
 7. "Now, one of my favorite ways to use this knot is to make a necklace from cord. Because all you have to do is slide the knots to loosen or tighten your necklace!
 - a. Now we are going to make necklaces and in the end, tie them off using a double fisherman's knot.
 - b. Spend some time making necklaces or friendship bracelets (you can have the girls incorporate different knots into their pieces).

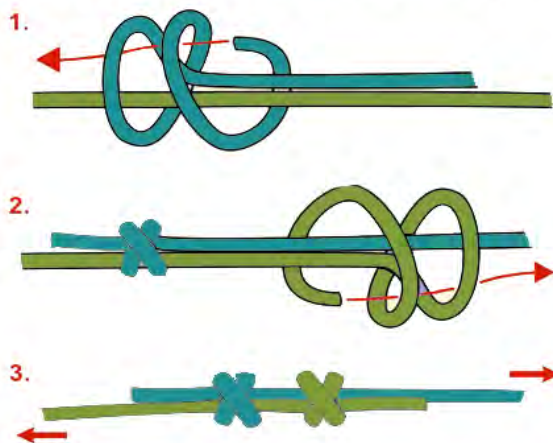

➔ TRUCKER'S HITCH

Materials Needed: 1 piece of rope for each girl – about 6 feet long, 2 chairs (or other sturdy objects)

8. "Now we're going to learn how to tie a trucker's hitch. A trucker's hitch is used to tighten and secure items."
 - a. Tie one end of the 6 foot rope to one of the chair's leg.
 - b. About mid-way on the rope tie a slip knot in the middle of the line.
 - c. Make a wrap around the leg of another chair. Feed the free end through the loop of the slip knot.
 - d. Using the loop as a pulley, pull down with the free end as tight as you can and secure the knot with two half hitches around one or both lines. (Not sure what a half hitch is? Research it!)
9. Let the girls practice tying the knot a few times. If some girls are struggling, try pairing them up with girls who are tying the knot well.
10. "Gee those are some great trucker hitches! Can anyone come up with any ways that we could use this knot?"
 - a. Tying down boats to cars, securing items in trailers, tying down rain flies on tents.
 - b. If you have the resources available, try to give the girls time to practice tying a trucker's hitch in a "real life" scenario.

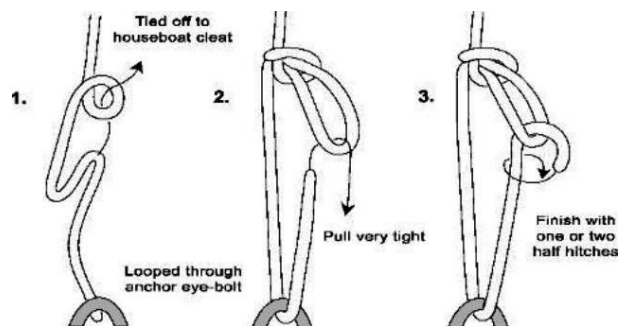

➔ SHEET BEND

Materials Needed: 2 pieces of rope for each girl – about 3 feet long that are different diameters

11. “Stellar! Now we are going to learn how to tie a sheet bend. A sheet bend is used to tie two ropes of unequal thickness together.”

- a. Form a bight in the thicker rope and hold it in one hand.
- b. Pass the thinner rope through the bite and behind the other’s tail and standing ends in that order.
- c. Finally, tuck the smaller rope under itself to finish the knot.

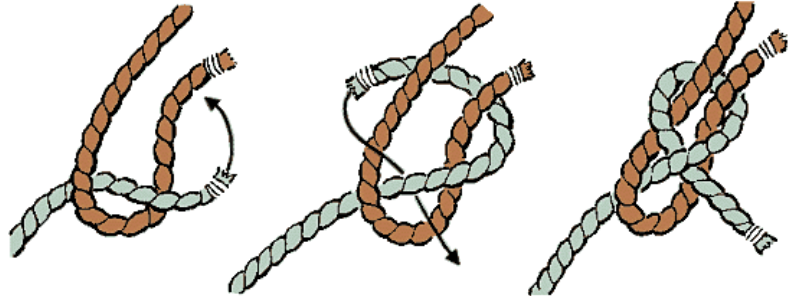

12. Let the girls practice tying the knot a few times. If some girls are struggling, try pairing them up with girls who are tying the knot well.

13. “Gee those are some great sheet bends!”

Step 2:

Learn the barrel hitch and how to tie a Swiss seat

1. Gather the girls up and explain “Today we are going to learn 2 more types of knots. But first, let’s review the knots we learned last time!”

- a. Review the truckers hitch, sheet bend, and a double fisherman’s knot. Refer to Step 1 for instructions.

➔ BARREL HITCH

Materials Needed: 1 piece of rope for each girl – about 5 feet long, Bucket (or cup) filled with water (enough to split the girls into smaller groups and have one each

2. “Now we are going to learn how to tie a barrel hitch. A barrel hitch is used when you need to lift a barrel or other container filled with liquid.”

- a. Stand the barrel on the lifting rope.
- b. Tie an overhand knot across the top.
- c. Spread the overhand knot until it embraces the top of the barrel.
- d. Join the ends with a bowline and lift.

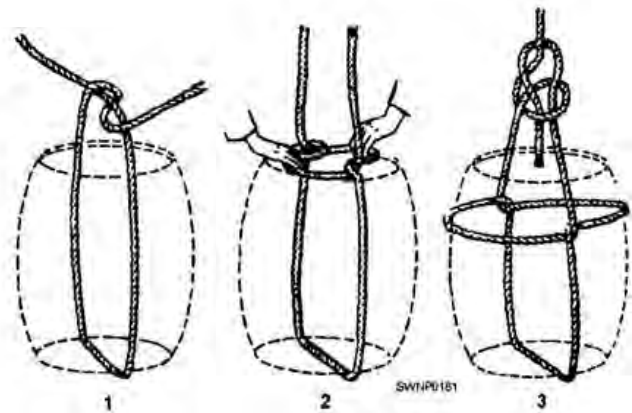

3. Let the girls practice tying the knot a few times. If some girls are struggling, try pairing them up with girls who are tying the knot well.

4. Have a quick competition and divide the girls into teams of 4 or less. The girls must work as a team to tie a bucket with the barrel hitch and carry it at least 10 feet without losing any water from the inside.

5. “Spectacular those are some great barrel hitches!”

➔ SWISS SEAT

Materials Needed: 1 piece of rope for each girl – about 10 feet long

6. “Now we are going to learn how to tie a Swiss seat. This can be used in an emergency situation if you need a harness.” Adapted from <http://timothygroup.org/rappellingropes/2013/9/9/how-to-tie-an-emergency-harness-swiss-seat>

- a. Make a bight in the center of the rope by folding it in half.
- b. Hold the bight on your non-dominant side hip. (If you are right handed, on your left. If you are left handed, on your right side.)
- c. Pull one end of the rope entirely around your waist. Both ends should now be in front of you.
- d. Tie a double overhand knot around your body at approximately waist level (ensure it is above your hips.) This is the belt/waist part of the harness. It doesn't need to be tight, just pulled comfortably around your middle.

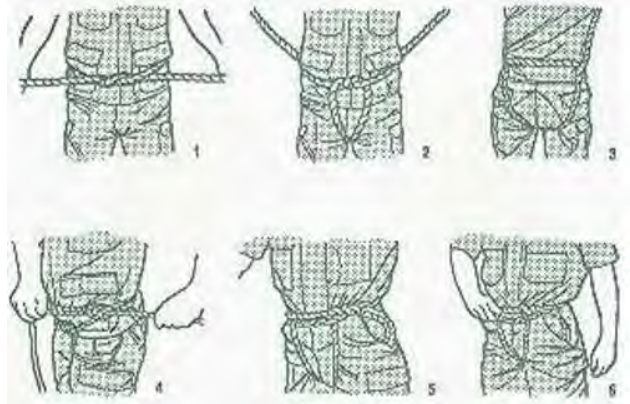

- e. Grab both ends of the rope and pull them under your body between your legs.
- f. Reach behind you and grab the two ropes the ropes should be pulled towards the small of your back. Position the ropes so they are on the outside edge of your bottom.
- g. Pass the ends over the outside of the belt portion and back through the side touching your body.

- h. Pull the rope up over your shoulders. Squat downward and stand up slowly a couple of times while pulling tension in the rope ends. Pull tightly and snugly while standing. You do not want any slack at this time.
- i. Continue to hold tension; pulling each end towards the opposing outsides of your body. Meet both ends on your non-dominant hand side.
- j. Tie a square knot with the two ends on your hip in order to secure the harness. Your knot should be clean and neat.
- k. Finish the harness by tying half a double fisherman's knot on the outside of the square knot.
- l. If you are using in an emergency situation, attach a carabiner to the front.

7. Let the girls practice tying the Swiss Seat a few times. If some girls are struggling, try pairing them up with girls who are tying the knot well.

8. “Wonderful, those are some great Swiss seats! Can anyone come up with any ways that we could use this knot?”

- a. Broken harness, need a harness to get down/up a canyon wall
- b. **“These harnesses are only meant to be used in emergency situations. If you are going someplace where you will need a harness, pack a manufactured harness. These are a safer and more reliable method.”**

9. Please do not use the Swiss seats for climbing activities. This is provided more as an informational piece. If you want to learn more about Swiss seats and how to use them while climbing, please contact an outside vendor.

Step 3:

Learn the monkey's fist and cobra stitch

1. Gather the girls up and explain "Today we are going to learn 2 more types of knots. But first, let's review the knots we learned last time!"
 - a. Review the truckers hitch, sheet bend, bowline, barrel hitch, and Swiss seat. Refer to Steps 1 and 2 for instructions.

➔ MONKEY'S FIST

Materials Needed: 1 piece of parachute cord for each girl – about 3 feet long, 1 marble per girl

2. "Now we are going to learn how to tie a monkey's fist. A monkey's fist is used to weight the end of a heaving line."
 - a. Wrap three turns around your fingers. Pass the end through the middle.
 - b. Make three more turns around the first ones. Pass the end through the middle.
 - c. Make three more turns locking the previous turns and remove fingers.
 - d. Stuff a marble into the middle.
 - e. Tighten every turn.
3. Let the girls practice. It may take a few tries before figuring out the knot.
 - a. For more fun, turn your monkey fist into a necklace to wear!
4. "Spectacular those are some great monkey's fists! Can anyone come up with any ways that we could use this knot?"
 - a. When throwing something to someone in the water to hold onto.

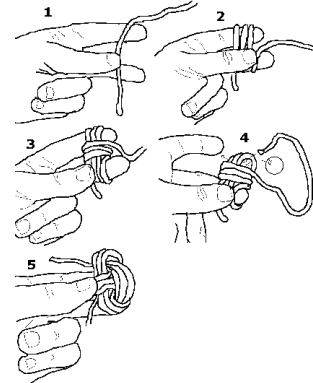

➔ COBRA STITCH

Materials Needed: 1 piece of parachute cord for each girl – about 6 feet long

5. "Geewiz! Now we are going to learn how to tie a Cobra Stitch. This knot takes a large amount of rope and condenses it into something smaller to carry around."
 - a. Make a loop and tie an overhand knot.
 - b. Tie a half knot around the loop and tighten.
 - c. Keeping the same rope in front, tie another half knot and tighten.
 - d. Keep repeating.
 - e. Leave the last several knots loose.
 - f. Tuck the ends inside the loose knots.
 - g. Tighten the loose half knots and trim the ends off.

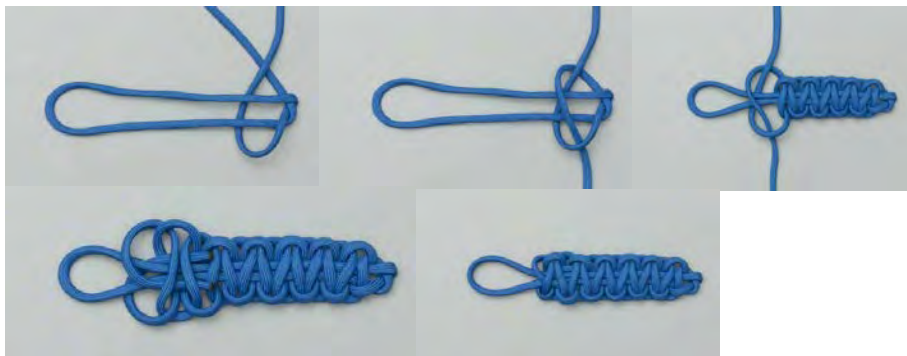

6. Let the girls practice. It may take a few tries before figuring out the knot.
 - a. For more fun: Add a carabiner or split key ring onto the loop and keep it with your outdoor gear.
 - b. For an even greater challenge: Can you turn the cobra stitch into a survival bracelet?
7. “Amazing those are some great cobra stitches! Can anyone come up with any ways that we could use this knot?”
8. Have some fun with these decorative knots. You might make some cobra stitches for younger girl scouts or a monkey fist to give to important people in the girls’ lives.

Resources:
Knot Handout

Outdoor Skills Patch | Knots – Cadettes

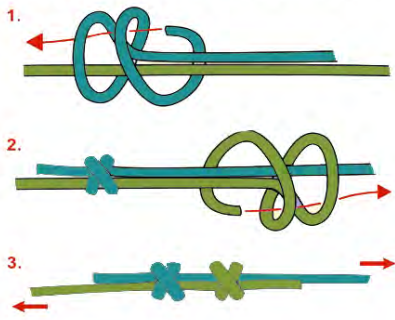

DOUBLE FISHERMAN'S

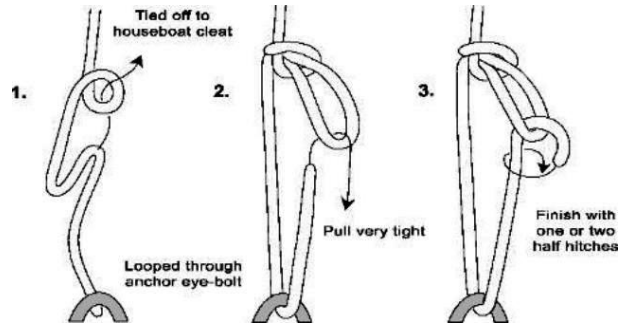

TRUCKER'S HITCH

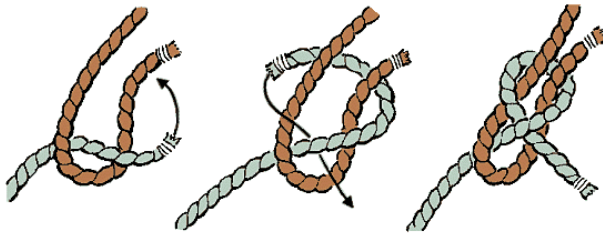

SHEET BEND

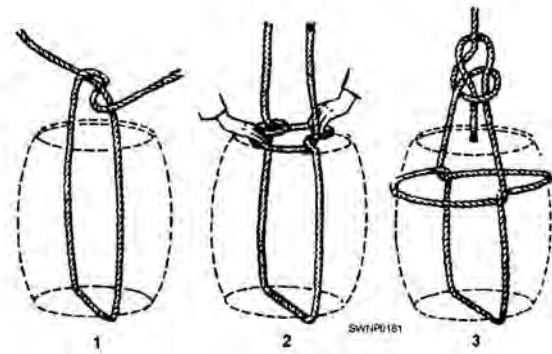

BARREL HITCH

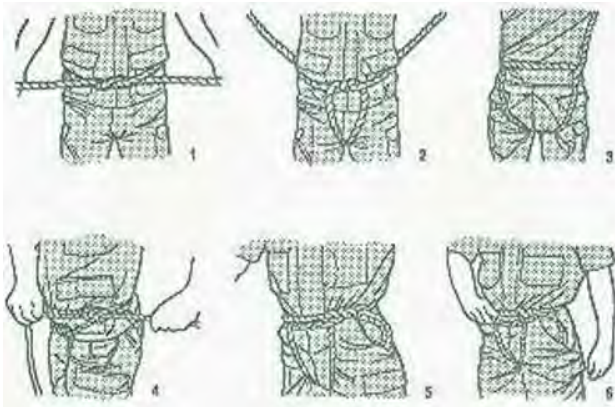

SWISS SEAT

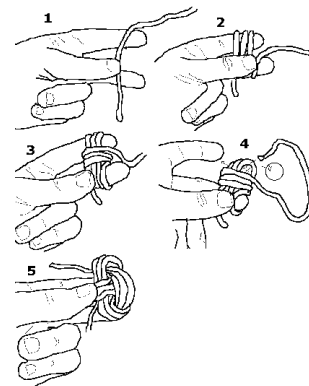

MONKEY FIST

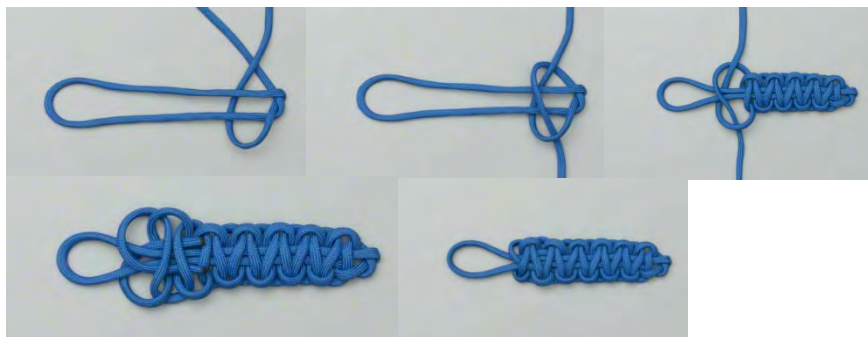

COBRA STITCH



Outdoor Skills Patch Knots – Seniors & Ambassadors



Learn the skills needed to thrive in an outdoor environment. Do you know how to tie knots and what to use them for? Do you want to learn how to lash?

PLEASE NOTE:

- This guide is written in a way that a girl can pick it up and go through the steps without having a Troop Leader lead the session for her.
- Feel free to use the internet to look for videos and other diagrams of how to tie the knots in this section as it may be easier to understand than written text.
- Try to space out each step between different time frames. Doing them one right after another might cause you to become disinterested and less engaged.

Step 1:

Learn to square, diagonal, and sheer lash

1. First we're going to review some knots that we've learned in the past (or they might be new to you).
 - a. Review the knots from the Brownie, Junior, and Cadette Knots curriculum guides or look online for resources:
 - i. Brownies: overhand, square, slip, overhand on a bight, and a figure 8 knot
 - ii. Juniors: water, double overhand, bowline, clove hitch, munter's hitch, quick release knot, figure 8 on a bight and with a follow through and monkey chain
 - iii. Cadettes: double fisherman's, trucker's hitch, sheet bend, barrel hitch, how to tie a Swiss seat, monkey's fist, and cobra stitch
 - b. Be sure you can demonstrate that you know how to tie these knots and why you'd use these knots.
2. Now that we've reviewed some knots, we're going to learn how to lash. Lashing is used to join together poles in order to create useful items. Today we are going to learn the most commonly used lashing methods.
3. Following the lashing methods below, make and keep miniature versions of the different types of lashing. You may also try combining different lashing techniques.
- 4.

➔ SQUARE LASHING

Materials Needed: 1 piece of rope for each girl – about 3 feet long, 2 sticks per girl of similar thickness

5. Start with a clove hitch around one pole.
6. Twist short end around long and wrap the rope around both poles, alternately going over and under each pole about three or four turns.
7. Tighten the lashing by surrounding it with three or four frapping turns.
8. Finish with two or three tight half hitches. Not sure what a half hitch is? Research it!

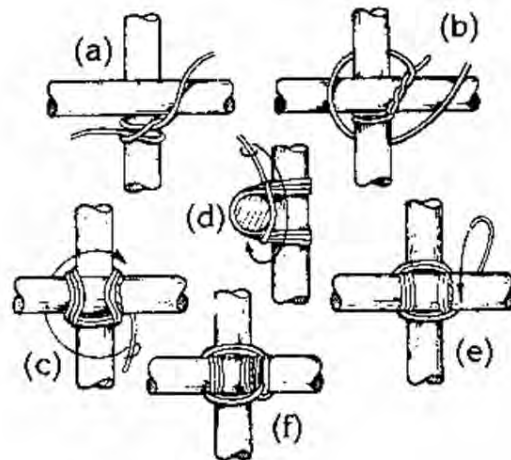

➔ **DIAGONAL LASHING**

Materials Needed: 1 piece of rope for each girl – about 3 feet long, 2 sticks per girl of similar thickness

9. Start with a single timber hitch around both poles. Not sure what a timber hitch is? Research it!
10. Wrap three or four turns around the two poles in one axis followed by three or four turns in the other axis.
11. Tighten the lashing by surrounding it with three or four frapping turns.
12. Finish with a clove hitch.

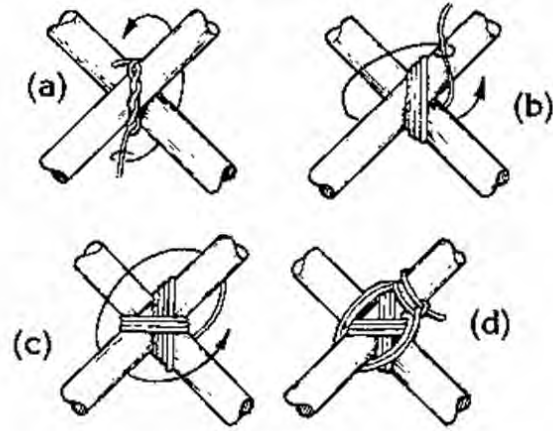

➔ **ROUND LASHING**

Materials Needed: 1 piece of rope for each girl – about 3 feet long, 2 sticks per girl of similar thickness

13. Start with a clove hitch around both poles.
14. Wrap six or eight turns around the two poles.
15. Finish with another clove hitch.
16. Two round lashings can be used to make a longer pole.

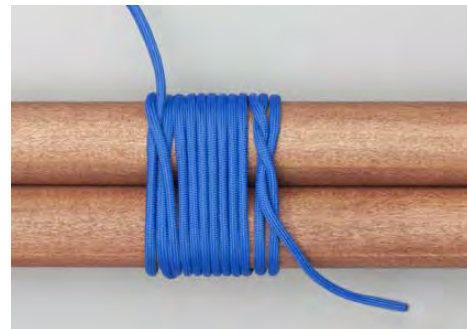

➔ **SHEAR LASHING**

Materials Needed: 1 piece of rope for each girl – about 3 feet long, 2 sticks per girl of similar thickness

17. Tie a clove hitch around one pole.
18. Wrap both poles with a simple lashing.
19. Wrap the lashing with a two or three tight frapping turns.
20. Tie off the end with a clove hitch.
21. Spread the poles to make shear legs.

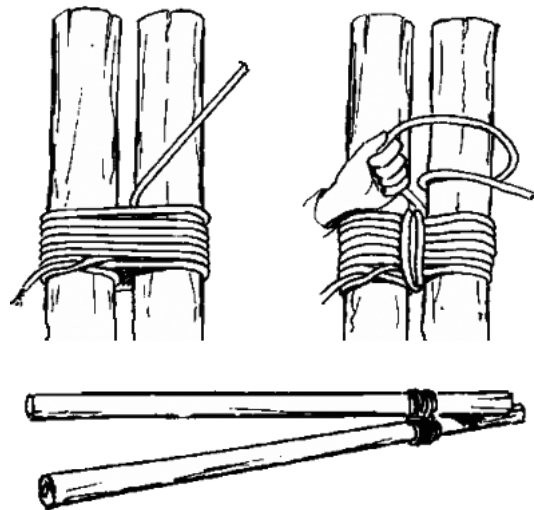

➔ **TRIPOD LASHING**

Materials Needed: 1 piece of rope for each girl – about 3 feet long, 3 sticks per girl of similar thickness

22. Start with a clove hitch around one pole.
23. Wrap about six racking turns around the three poles weaving in and out between them.
24. Make two or three tight frapping turns in the two gaps.
25. Finish with a clove hitch.
26. Cross the two outside poles to form the tripod.



Step 2:

Lash together a floating campfire

(or something similar if you don't have the water resources to do a floating campfire)

Materials Needed: Buoyant platform (logs, pvc pipes, or old foam blocks), kindling sized sticks, tarp, sand, fire wood, matches, marshmallows

1. Review the lashing types from Step 1.
2. Start with a platform. The platform must be buoyant – and stable enough – to hold the weight of the frame, the foundation, and the fire layer itself. Options for the platform include: logs 8-10" in diameter, large and enclosed PVC pipes, and old foam blocks.
3. These foundation pieces need to be lashed together to form a solid, level base that floats pretty high in the water.
4. A cross frame is then applied on top of the base and is used to lay a "floor" for the rest of the fire to sit upon. Round lash together kindling sticks for this layer.
5. Lay a tarp down on top of the floor with a layer of sand on top as an insulation/ground layer of the fire.
6. Now that everything is pieced together, build your fire, float it onto a lake, and get ready to roast some marshmallows!

Step 3:

Lash together a table

Materials Needed: Sticks, multiple pieces of rope of various lengths

1. Review the lashing types from Step 1.
2. Lash together a table.
 - a. The only requirement is the table should be at least 3 feet from the ground and 4 feet long.
 - b. The table should be able to hold at least 20 pounds of weight.

Resources:

Knot Handout

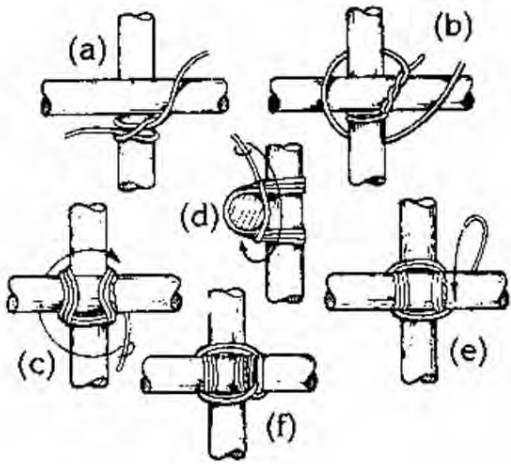

SQUARE LASHING

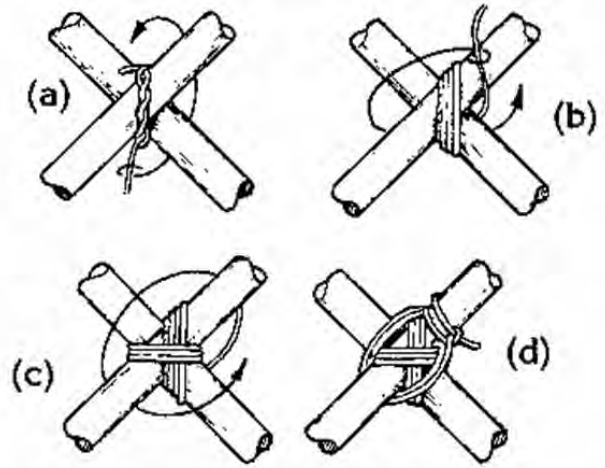

DIAGONAL LASHING

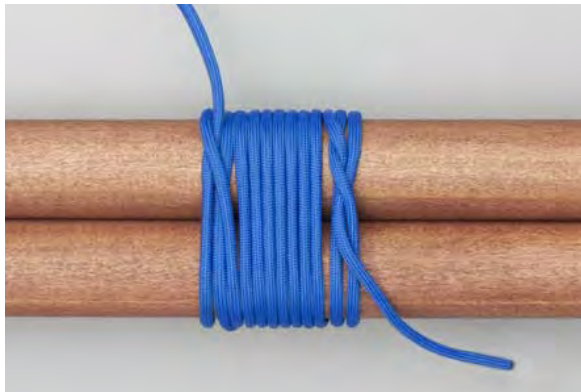

ROUND LASHING

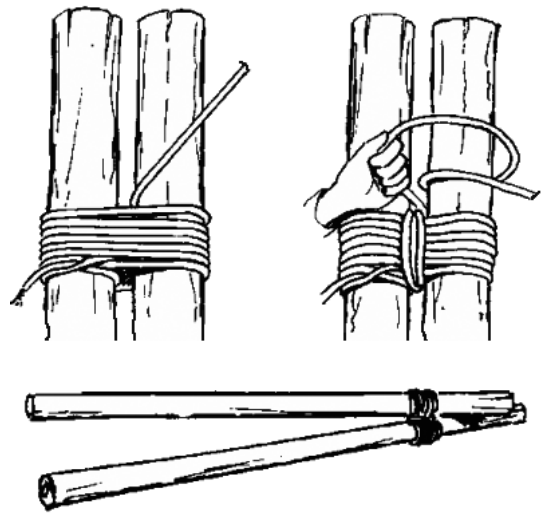

SHEAR LASHING



TRIPOD LASHING